

CAD FILE:

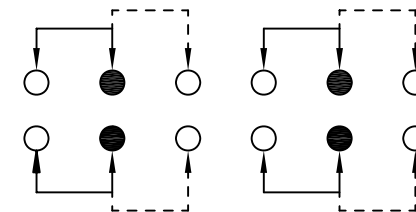

SCHEMATIC (SHORTING)

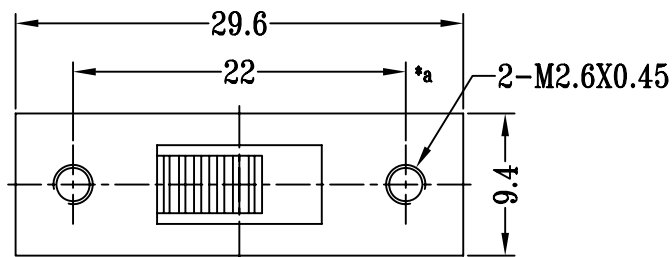
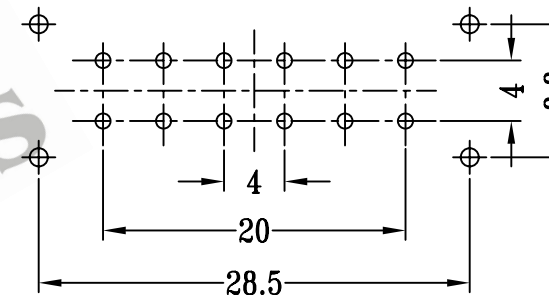
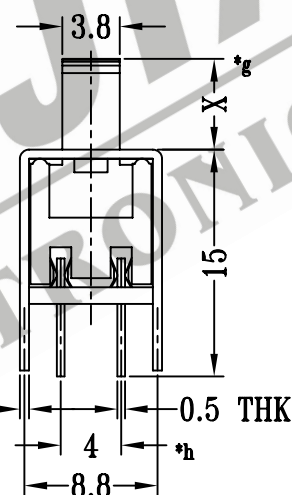
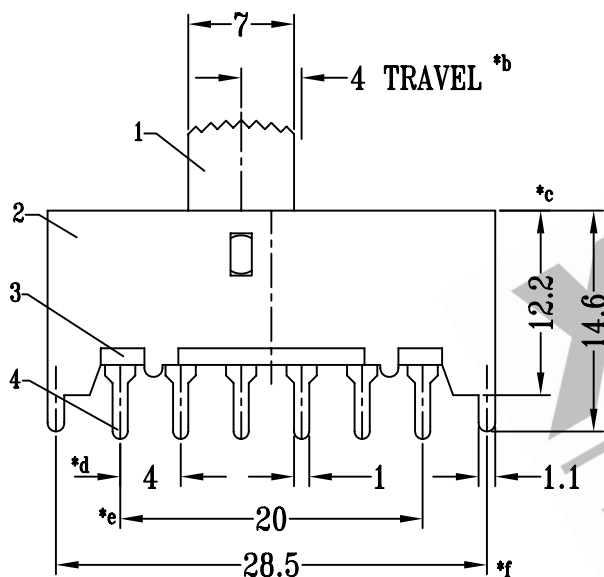

P.C.B LAYOUT

注:带"*"表示关键尺寸(8个)

NO.	PART NAME	MATERIAL	Q'TY	FINISHING	TOLERANCE UNLESS SPECIFIED	SHENZHEN XIEJIA ELECTRONICS CO.,LTD.				
8						ISSUE	DATE	DESCRIPTIONS		APPD.
7	CONTACT CLIP	PBS STRIP	4	Ag PLATED	WITHIN: 1.5±0.1mm OVER : 1.5±0.2mm					
6	STEEL BALL	STEEL	2	NATURAL				DRWG NO.: XJ-DR-SS42H03-00		
5	SPRING	STEEL WIRE	1	TEMPER				DWN.	ZHOUYU	2003-8-19
4	TERMINAL	BRASS STRIP	12	Ag PLATED OVER Ni PLATED	TITLE : VERTICAL SLIDE SWITCH	UNIT : MM		CHK'D	FANGYING	2003-8-19
3	BASE	PHENOLIC RESIN	1	BLACK	MODEL: SS-42H03	SCALE: 2:1		APPD.	KANGXINAN	2003-8-19
2	FRAME	STEEL STRIP	1	BLACK/Ni PLATED	ALL MATERIALS MUST BE COMPLIANT TO ROHS					
1	KNOB	POM	1	BLACK						